

WOOD CHIPS



Northwest Indiana Woodworkers Association

Volume 17, Issue 3 March 2013

President's Corner

Greetings Woodworkers, I've been working out in the shop getting things ready to start making projects. I want to thank several members, you know who you are, that I phoned with various questions. That is what is great about our club. You can call someone on the roster and if they can't solve the problem, they know who can. If things keep moving along I may be able to have a shop visit this year! I am sure a shop visit is as exciting to host as it is to attend. If you would like to have a shop visit contact Dick Sader.

We will miss you Tom Howarth Tom was one of the kindest persons I ever met. He always looked at members projects and highlighted the good things about it. Tom was quite the woodworker; even though he considered himself average. He made furniture, crafts, turned the lathe and would try just about anything. He was willing to let members use his shop for toy projects. He considered his shop just "good enough" not great. Well Tom is now working with the Great Carpenter in His shop. Tom it was a pleasure to have known you. God Bless You.

March Speaker is Don Good well known for his abilities and techniques in sharpening tools. He is also well known for his carvings. Many of you may have met him at Woodcraft, formerly in Merrillville, Indiana. He is a member of the Duneland Woodcarvers Club. He will be at our March 28 membership meeting doing sharpening demonstrations on various types of tools. If you have a hard to sharpen tool or a tool that you don't know how to sharpen, bring it to the meeting and we will see if we can get you the knowledge you need to sharpen your tool.

Committee Meeting There were some lucky members that attended the committee meeting this month. IRWIN asked us to assess their new product and provide feedback. Marples Woodworking Series saw blades were distributed to members attending the committee meeting with the understanding to use the product and provide feedback.

Don't Forget to Sign up for the Booth at Duneland Woodcarvers Show Woodland Park, 2100 Willow Creek Rd. Portage, Indiana
Setup Friday 4pm, Show: Sat. 10am-5pm Sun. 10am-4pm

We need help demonstrating scroll sawing, woodworking, & talking about our fine club at the booth. We need items to display but not sell. Sign up at the meeting or call Marcia or John Hunter.

Toy Program If you have any patterns that you would like to add to the toy making file please give them to Ken Garbe or Marcia Lichnerowicz. They need to make safe toys. No pull cords. Toys cannot be a choking hazard. Ron Benson has toy parts. John Hunter has wheels and will be ordering axles very soon. If you have toys that need painting and are unable to paint let us know early. Right now we do not have a painting group but are working on this.

Executive Board Meeting is April 1. If you have something that you need brought up for the club let the Executive Board Members know.

April's program is the 2x4 challenge Time to get started on the 2x4 challenge. Have fun!

See you at the meeting!

Your president, Marcia Lichnerowicz

From the Treasurer

Brother woodworkers; this year our annual educational raffle sales should be a great one with the members support in selling, buying tickets to it. The prize this year is a Bosch 3 piece tool combo kit consisting of an 18 volt lithium ion battery system. The tools are a Drill, Saws all, and a Skill saw. Tickets are only \$5.00 or five for \$20.00. The money from this event goes toward our educational program like, speakers; buying supplies for our toy program, library, and helping those that want to learn wood working. There are only 500 tickets to sell; I think we can sell them all.

Norm Johnson is the chairman in charge, and Ron Benson is co-chairman. If you want tickets, we can send them to you. Call; Ron Benson at; 762-8416, or Norm Johnson at; 769-6519.



Raffle Main Prize

On another note, your yearly membership DUES are being accepted. All dues are due by May 1st. in case you forgot, DUES are only \$25.00. Members can pay at your monthly meeting, or send it to our P.O. Box, which is NIWA, P.O Box 1602, Portage Indiana, 46368. If you pay before May, you qualify for an achievement point.

Thank you.

Ron Benson

SHOW AND TELL



Mick King



Rodney Foster



Joe Jurisa



Dick Sader



Wally Richardson



Ron Benson



Max Hernick



John Hunter



Jesse Day



Marcia Lichnerowicz

SHOP JIGS



Denny McCoole



Jim Jones



John Hunter



John Hunter



Max Hernick



John Novak

ITEMS FOR SALE

If you have any wood working related items that you wish to sell through the newsletter please contact John Hunter john.b.hunter@frontier.com Include a description and the price you are selling them for, also how you may be contacted.

If you are looking for a tool that another member would like to sell you can place a wanted ad in the newsletter, just contact John Hunter at john.b.hunter@frontier.com

CALENDAR OF EVENTS

2013

March 28th Membership Meeting at Hidden Lake 7:00 PM
April 13th & 14th Duneland Carvers Show at Woodland Park
April 1st Executive Board Meeting at Portage Library 7 PM
April 16th Committees Meeting at Marcie's home 7:00 PM
April 25th Membership Meeting at Hidden Lake 7:00 PM 2 x 4 Challenge
May 21st Committees Meeting at Marcie's home 7:00 PM
May 23rd Membership Meeting at Hidden Lake 7:00 PM
June 18th Committees Meeting at Marcie's home 7:00 PM
June 27th Membership Meeting at Hidden Lake 7:00 PM
July 1st Executive Board Meeting at Portage Library 7 PM
July 16th Committees Meeting at Marcie's home 7:00 PM
July 25th Membership Meeting at Hidden Lake 7:00 PM
August 1st Set Up Club Booth at Lake County Fair 9 PM
August 2nd – 5th Club Booth at Lake County Fair 10 AM – 10 PM
August 20th Committees Meeting at Marcie's home 7:00 PM
August 22nd Membership Meeting at Hidden Lake 7:00 PM
August 25th Club Picnic at Hidden Lake Park 12 Noon
September 17th Committees Meeting at Marcie's home 7:00 PM

September 26th Membership Meeting at Hidden Lake 7:00 PM
October 7th Executive Board Meeting at Portage Library 7 PM
October 15th Committees Meeting at Marcie's home 7:00 PM
October 24th Membership Meeting at Hidden Lake 7:00 PM
November 19th Committees Meeting at Marcie's home 7:00 PM
November 14th Membership Meeting at Hidden Lake 7:00 PM Toy Program
December 17th Committees Meeting at Marcie's home 7:00 PM
December 19th Membership Meeting at Hidden Lake 6:00 PM Christmas Party,
Installation and Awards

Bob Flexner's Finishing Tips

<http://www.thefinishingstore.com/>

TIP: Store Water-Based Brushes

Water-based finishes dry in several hours, so it's easy to apply two or three coats in a day. In other words, unlike with oils and varnishes, you can complete a finishing project in one day using a water-based finish.



Storing Water-Based Brushes

The rapid drying occurs not only on the wood but also on the brush. Instead of washing the brush between each coat, which is perfectly legitimate, it's much more efficient to just store the brush. There are two easy ways to do this:

- Hang the brush in a jar of water. (Notice in this photo that I have drilled an additional hole in the brush handle so that I can hang the brush without its bristles touching the bottom of the jar. When a brush rests against the bottom, its bristles can become permanently bent, which essentially ruins the brush for good work.
- Wrap the brush in plastic wrap. Wrap airtight so air can't get to the finish on the bristles and dry it. You can store a brush for several days this way without problems.

Drill Press Inserts

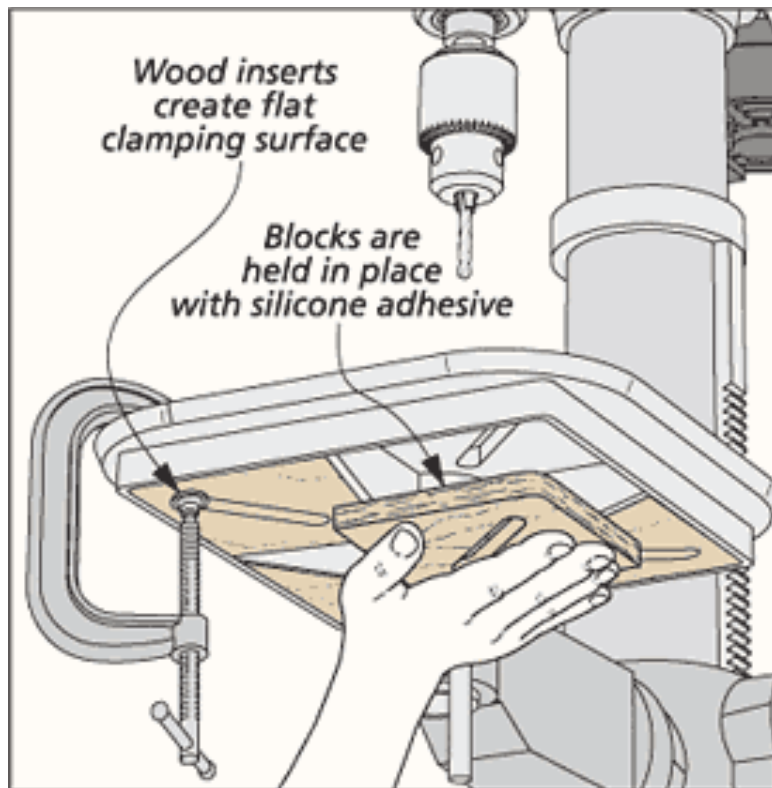

As any drill press user knows, trying to clamp a workpiece directly to the cast iron table can be trying. The reinforcing ribs on the underside of the table can sometimes make positioning and tightening a clamp nearly impossible. After struggling with this problem for far too long, I resolved to solve it.

As you can see in the drawing, I simply cut plywood inserts to fill the spaces between the ribs and provide a flat, solid clamping surface on the underside of the table. I cut slots in the inserts to match the slots in the table so I can still make use of this option. Then the inserts are just stuck in place with silicone adhesive.

Now clamping a workpiece to the table is quick and effortless. And my only regret is not having made this modification a lot sooner.

Good Woodworking,

Ted Raife

Online Editor, *Woodsmith*